

Manual Supplement

Manual Title:	725 Product Overview	Supplement Issue:	3
Part Number:	1549644	Issue Date:	10/02
Print Date:	January 2000	Page Count:	5
Revision/Date:			

This supplement contains information necessary to ensure the accuracy of the above manual.

Change #1

On page 7, Table 4, add the following Key Functions:

① 13	ⓈⓂⓁ	Disables Shut Down Mode
① 13	ⓈⓂⓇ	Enables Shut Down Mode

Change #2

On page 2, under **Standard Equipment**, add the following:

- Spare Fuse

On page 9, replace Figure 4 and add the following text:

Replacing the Fuses

The calibrator comes equipped with three 0.05A 250V socketed fuses to protect the calibrator.

⚠Warning

To avoid electrical shock, remove the tests leads form the calibrator before opening the battery door. Close and latch the battery door before using the calibrator.

The fuses can be removed and checked for resistance. A value of $< 10 \Omega$ is still good. Problems while measuring with the right jacks indicate that F3 may have opened. Problems while measuring or sourcing with the center jacks or the TC jacks indicate that F2 may have opened. If you can't measure or source current with the left jacks, F4 may have opened. To replace the fuses, refer to Figure 22 and perform the following steps:

1. Turn the calibrator off, remove the test leads from the terminals, and hold the calibrator face down.
2. Using a flat-blade screwdriver, turn the battery door screws 1/4-turn counterclockwise and remove the battery door.
3. Remove and replace the damaged fuse.
4. Replace the battery door and secure it by turning the screws 1/4-turn clockwise.

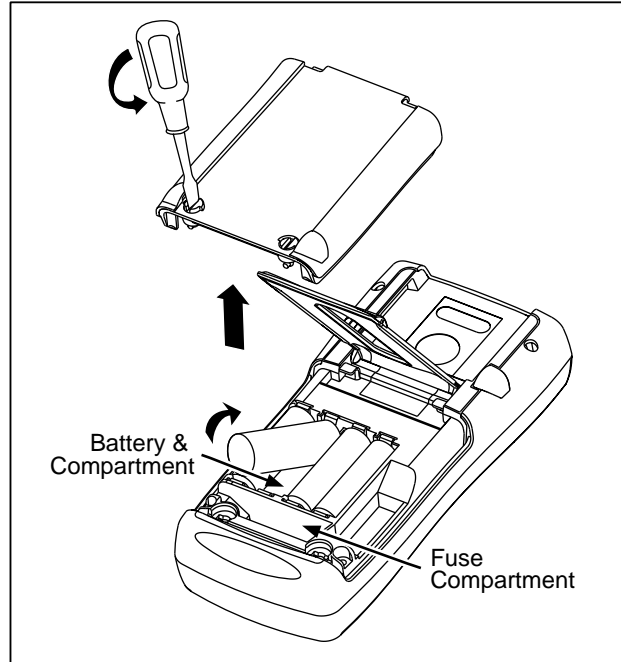

Figure 4.

sh38_1.eps

On page 9, add the following to **Replacement Parts** table:

23	Fuse 0.05A/250V (5 Pack)	1593766	1
----	--------------------------	---------	---

On page 10, Figure 5, add the view of the fuses as shown in Figure A.

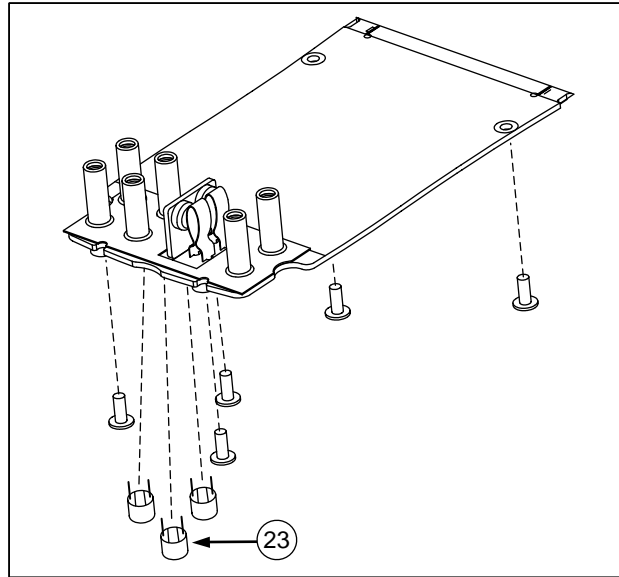

Figure A.

figure_a.eps

Change #3

On page 11, under *Specifications*, replace the first sentence with the following:

Specifications are based on a one year calibration cycle and apply from +18 °C to +28 °C unless stated otherwise.